

NOBILIS

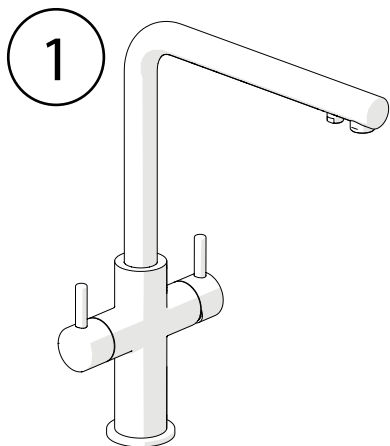

AQ96823/3VB

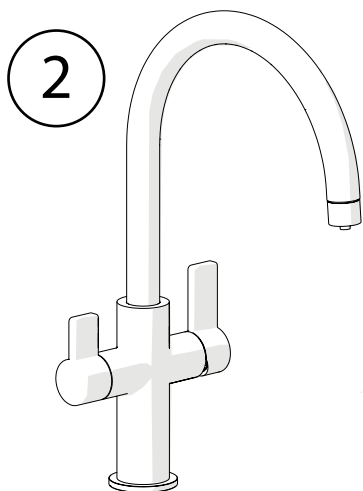

FL96824/3VB

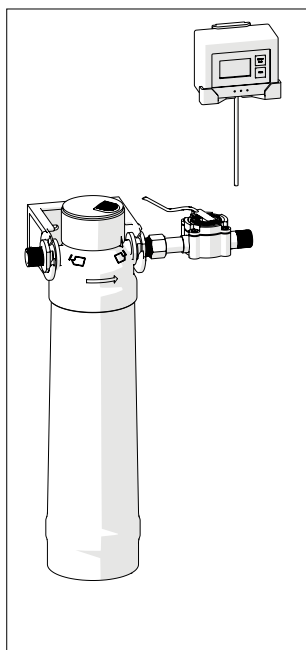



Not included / Non incluso

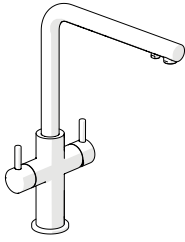
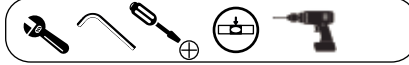

A

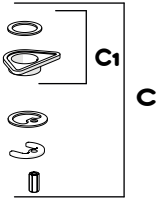

C1

C

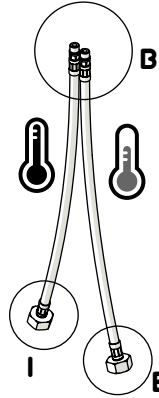

B



I

E

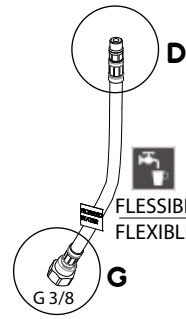

D

G 3/8

G

600 mm

F

H

FLESSIBILE / FLEX
G 3/8 - G 3/8

FLESSIBILE ACQUA FILTRATA
FLEXIBLE FILTERED WATER

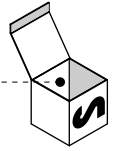











NON INCLUSI
NOT INCLUDED





RUBINETTI FILTRI CON CHIUSURA
FILTER VALVES WITH CLOSURE

- Funzionamento non possibile con un scaldabagno non pressurizzato
- Operation not possible with an unpressurized water heater

PRIMA DI INIZIARE / BEFORE STARTING



 <p>P bar</p>	 <p>2 MIN</p>	 <p>MAX 8</p> 	 <p>T</p>	 <p>°C</p>	 <p>MAX 80</p>	 <p>65 45</p> 
---	--	--	---	---	---	--

bar = 0.1 Mpa

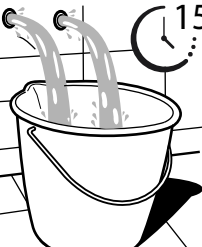





15s

STAFFA DI SUPPORTO
BRACKET

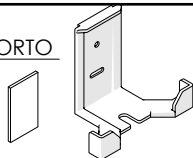

UNITÀ DI CONTROLLO DELLA CAPACITÀ DEL FILTRO
FILTER CAPACITY CONTROL UNIT

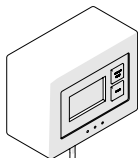

2 x 1.5 V (AA, LR6)
INCLUSI
INCLUDED

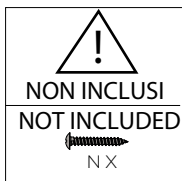

L=1400 mm

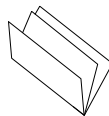

SENSORE DI PORTATA
FLOW SENSOR

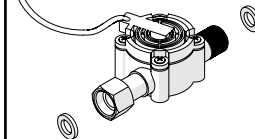

STAFFA DI SUPPORTO
BRACKET

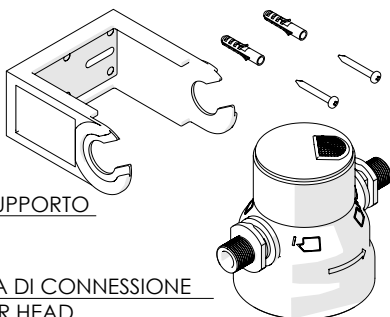

TESTA DI CONNESSIONE
FILTER HEAD

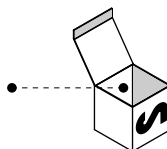

CARTUCCIA FILTRANTE
FILTER CARTRIDGE

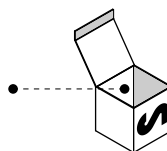
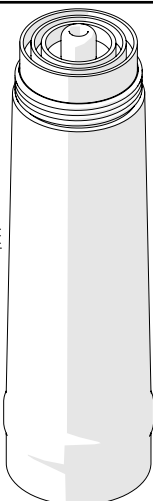
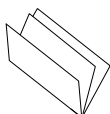

INDICE

DATI TECNICI FILTRO E AQA MONITOR.....	5
AVVERTENZE GENERALI DI INSTALLAZIONE E SICUREZZA.....	6
INSTALLAZIONE IDRAULICA.....	7-8
USO E STRUTTURA CARTUCCIA FILTRANTE.....	9
CAPACITÀ DEL FILTRO E IMPOSTAZIONE DEL BYPASS.....	10
MONTAGGIO STAFFA DI SUPPORTO E TESTA DI CONNESSIONE....	11
INSTALLAZIONE DEL CONTATORE ACQUA	12
INSTALLAZIONE CARTUCCIA FILTRANTE.....	13-14
REGOLAZIONE DEL DISPLAY AQA MONITOR	15
SOSTITUZIONE DELLA CARTUCCIA FILTRANTE.....	15
DISEGNO TECNICO E SCHEMA IMPIANTO.....	16
FUNZIONAMENTO MISCELATORE.....	17-18
SOSTITUZIONE CARTUCCE RUBINETTO.....	19
GRAFICI DI PORTATA.....	20-21
RIPARAZIONE GUASTI SISTEMA FILTRO.....	22
SOSTITUZIONE BATTERIE E SMALTIMENTO.....	23
PULIZIA RUBINETTO E NOTE.....	24

INDEX

TECHNICAL DATA FILTER AND AQA MONITOR	5
GENERAL INSTALLATION AND SAFETY WARNINGS	6
HYDRAULIC INSTALLATION	7-8
USE AND STRUCTURE OF THE FILTER CARTRIDGE	9
FILTER CAPACITY AND BYPASS SETTING	10
ASSEMBLY OF SUPPORT BRACKET AND CONNECTION HEAD	11
INSTALLING THE WATER METER	12
FILTER CARTRIDGE INSTALLATION	13-14
ADJUSTING THE AQA MONITOR DISPLAY	15
REPLACING THE FILTER CARTRIDGE	15
TECHNICAL DRAWING AND SYSTEM DIAGRAM	16
MIXER OPERATION	17-18
CARTRIDGES REPLACEMENT TAP.....	19
FLOW CHARTS	20-21
TROUBLESHOOTING FILTER SYSTEM	22
BATTERY REPLACEMENT AND DISPOSAL	23
CLEANING TAP AND NOTES.....	24

DATI TECNICI FILTRO E AQA MONITOR

Dimensioni e peso		M200	AQA monitor
Altezza senza staffa	mm	360	–
Altezza con staffa	mm	385	–
Ø cartuccia filtrante	mm	88	–
Dimensioni unità contatore (L x A x P)	mm	–	80 x 47 x 30
Condizioni operative		M200	AQA monitor
Filettatura di attacco (in out)		¾" (filettatura esterna BSP)	¾" interno – ¾" esterno
Portata nominale	l/h	180	–
Pressione d'esercizio	bar	tra 2 e 8	–
Pressione dell'acqua in entrata	bar	>1.2	2–8
Perdita di carico a 180 l/h ¹	bar	0.60	–
Temperatura di ingresso dell'acqua (min./max.)	°C	tra +4 e +30	tra +4 e +30
Temperatura ambiente (min./max.)	°C	tra +4 e +40	tra +4 e +40
Capacità di flusso	l/min	–	tra 0.8 e 15
Deviazione del flusso	%	–	+/-5
Posizione di montaggio		orizzontale/verticale	orizzontale
Volume minimo di risciacquo	l	2	–

¹ Con impostazione di bypass "2" e montato con un tubo flessibile DN8 da 1.5 m in ingresso e in uscita.

TECHNICAL DATA FILTER AND AQA MONITOR

Dimensions and weights		M200	AQA monitor
Height without bracket	mm	360	–
Height with bracket	mm	385	–
Filter cartridges Ø	mm	88	–
Counter dimensions (W x H x D)	mm	–	80 x 47 x 30
Operating conditions		M200	AQA monitor
Connection thread (in out)		¾" (BSP male)	¾" internal – ¾" external
Nominal flow rate	l/h	180	–
Operating pressure	bar	2 to 8	–
Input water pressure	bar	>1.2	2–8
Pressure loss at 180 l/h ¹	bar	0.60	–
Water inlet temperature (min./max.)	°C	+4 to +30	+4 to +30
Ambient temperature (min./max.)	°C	+4 to +40	+4 to +40
Flow capacity	l/min	–	0.8 to 15
Flow deviation	%	–	+/-5
Mounting position		horizontal/vertical	horizontal
Minimum flush volume	l	2	–

¹ With bypass setting "2" and mounted on both sides with a 1.5-m-long DN8 hose at the inlet and outlet.

AVVERTENZE GENERALI DI INSTALLAZIONE E SICUREZZA

- A monte del sistema di filtrazione deve essere installata una valvola di chiusura (non inclusa) 
- La cartuccia filtrante BWT può essere utilizzata solo con acqua fredda che soddisfa i requisiti di legge per la qualità dell'acqua potabile.
- Per preservare l'acqua potabile attenersi a tutte le prescrizioni valide nei singoli paesi in materia di installazione (ad es. DIN 1988, EN 1717), alle condizioni generali in materia di igiene e ai dati tecnici.
- Nella testa di connessione sono integrate due valvole di non ritorno secondo la norma DIN EN 13959.
- Il luogo d'installazione deve essere protetto dal gelo e al riparo dai raggi diretti del sole. Non installare nelle vicinanze di fonti di calore e di fiamme libere.
- Il sistema di filtrazione non deve entrare in contatto con sostanze chimiche, solventi e vapori.
- La testa di connessione non deve mai essere sotto pressione nella rete idrica per lunghi periodi senza la cartuccia del filtro montata.
- La testa di connessione deve essere sostituita dopo 5 anni.
- Il sistema di filtrazione può essere azionato verticalmente od orizzontalmente:
 - Verticalmente: lasciare a terra uno spazio libero di 65 mm per facilitare la sostituzione del filtro.
 - Orizzontalmente: la cartuccia filtrante deve poggiare a terra.
- Per alcuni gruppi di persone (ad es. persone immunocompromesse, neonati) si raccomanda di far bollire l'acqua del rubinetto prima del consumo. Ciò vale anche per l'acqua filtrata.
- **Periodi di inattività:**
 - da 2 giorni: sistema di risciacquo del filtro con 2 litri d'acqua
 - a partire da 4 settimane: è necessario sostituire la cartuccia filtrante

GENERAL INSTALLATION WARNINGS AND SAFETY

- A shut-off valve must be installed upstream of the filtration system (not included) 
- The BWT filter cartridge can only be used with cold water that meets the legal requirements for drinking water quality.
- Comply with all country-specific installation regulations (e. g. DIN 1988, EN 1717), general hygiene conditions and technical data relating to the protection of drinking water.
- Two non-return valves in accordance with DIN EN 13959 are integrated in the filter head.
- The installation location must be protected against frost and direct sunlight. Do not install the unit near any sources of heat or open flame.
- The filter system must not come in contact with or be exposed to any chemicals, solvents and vapours.
- The filter head must never be under water mains pressure for long periods without the filter cartridge mounted in place.
- The filter head must be replaced after 5 years in service.
- The filter system can be operated in either a vertical or horizontal position:
 - Vertical: Leave approx. 65 mm clearance above the ground to facilitate filter replacement.
 - Horizontal: The filter cartridge must rest on the ground.
- For certain groups of people (e.g. immunocompromised persons, infants) it is recommended to boil tap water before consumption. This also applies to filtered water.
- **Breaks in operation:**
 - Lasting 2 days or longer: Rinse filter system with 2 litres of water
 - Lasting 4 weeks or longer: Filter cartridge must be replaced

INSTALLAZIONE IDRAULICA

HYDRAULIC INSTALLATION

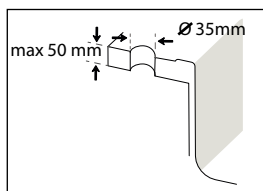
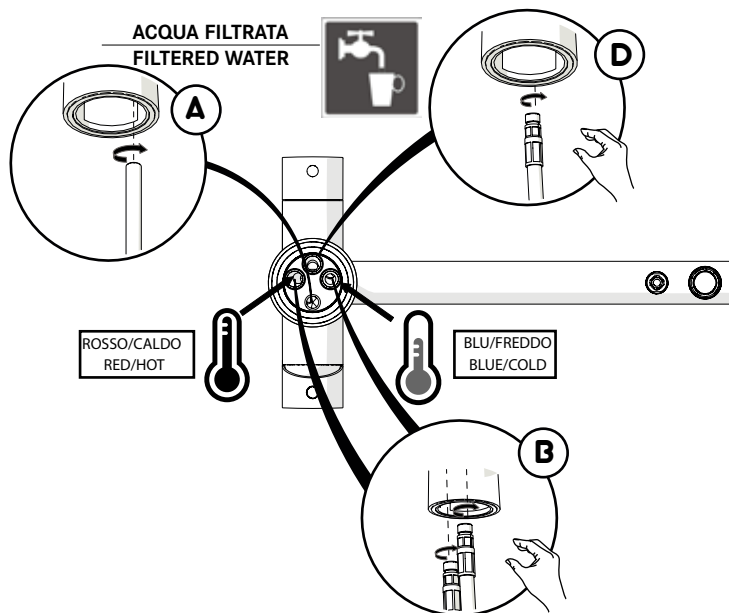

opzionale per lavelli sottili
optional for thin sinks

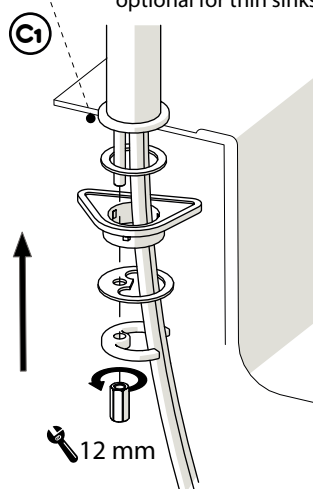
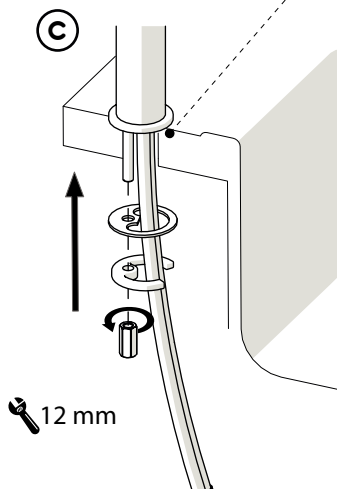

RUBINETTO
TAP

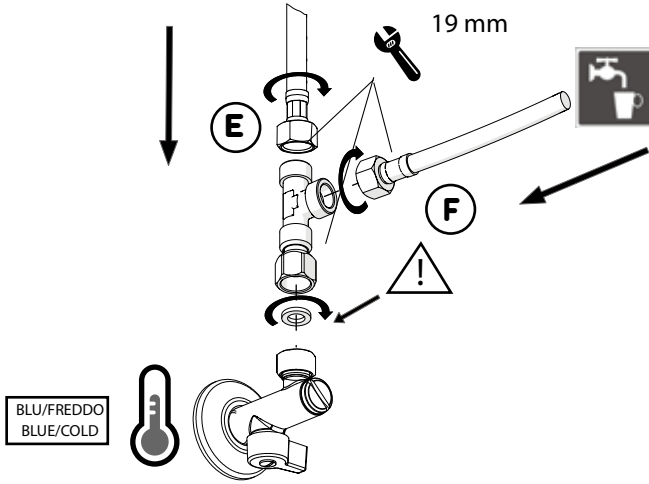

RUBINETTO
TAP

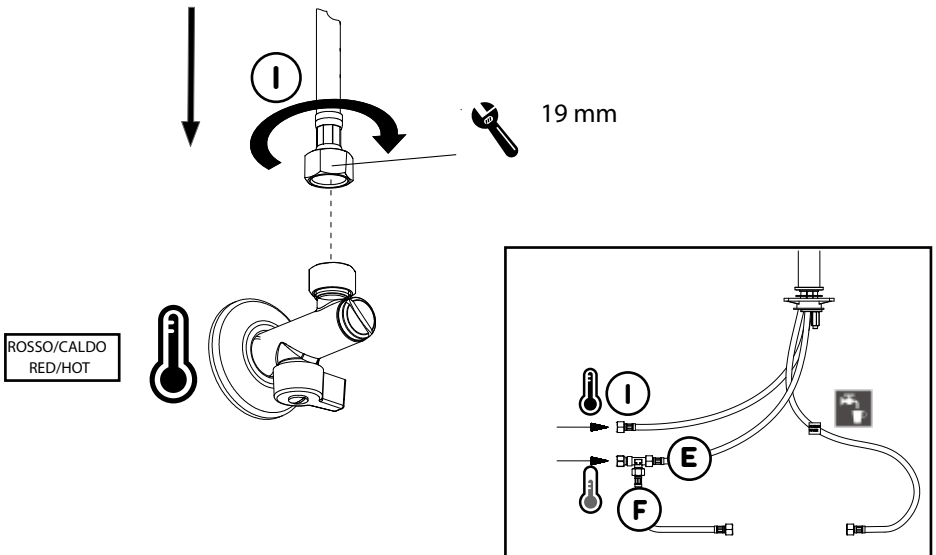

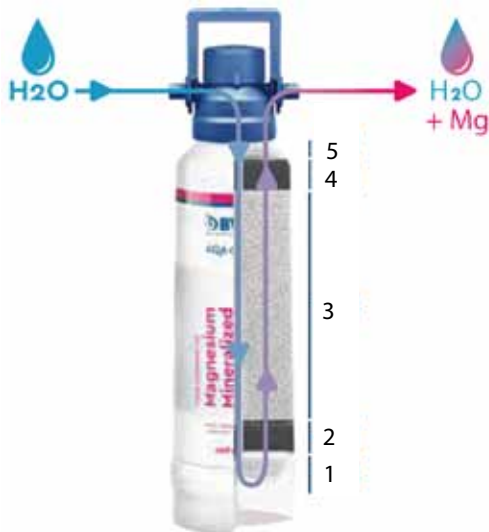
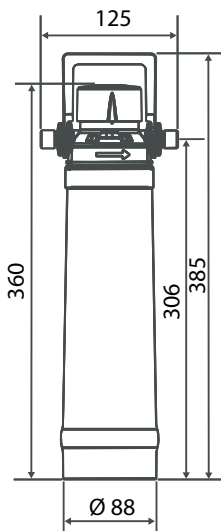

USO E STRUTTURA CARTUCCIA FILTRANTE

La cartuccia filtrante BWT AQA drink MP200 raffina l'acqua del rubinetto trasformandola in acqua mineralizzata al magnesio in cinque stadi di filtrazione

- 1 - La prefiltrazione filtra le particelle come sabbia o ruggine.
- 2 - La prefiltrazione a carboni attivi rimuove la materia organica per proteggere lo scambiatore di ioni.
- 3 - Lo scambiatore di ioni ad alte prestazioni riduce la durezza complessiva dell'acqua potabile e protegge così gli apparecchi dai depositi di calcare. Rilascia il prezioso magnesio minerale e riduce i metalli pesanti come il rame, il piombo e il nichel.
- 4 - La filtrazione a carbone attivo riduce le sostanze in grado di alterare l'odore e il gusto, ad es. il cloro.
- 5 - La filtrazione fine trattiene anche le particelle più piccole.

La testa di connessione AQA drink è dotata di un Aquastop, che impedisce la fuoriuscita involontaria di acqua durante l'installazione del filtro. Attraverso la funzione di bypass sulla testa di connessione, è possibile impostare lo spreco, quella quantità d'acqua che può essere filtrata solo con le fasi 4 e 5.

USE AND DESIGN FILTER CARTRIDGE

The BWT AQA drink MP200 filter cartridge refines your tap water into Magnesium Mineralized Water in five filtration stages.

- 1 - Prefiltration filters out particles such as sand or rust.
- 2 - Activated carbon pre-filtration removes organic matter to protect the ion exchanger.
- 3 - The high-performance ion exchanger reduces the overall hardness of drinking water and thus protects equipment from limescale deposits. It releases the valuable mineral magnesium and reduces heavy metals such as copper, lead and nickel.
- 4 - Activated carbon filtration reduces odour and substances that lend water an unpleasant taste, such as chlorine.
- 5 - Fine filtration captures even the finest particles.

The AQA drink filter head is fitted with an Aquastop, which prevents unintentional leakage of water during filter installation. The waste – i.e. that amount of water that can only be filtered out by steps 4 and 5 – can be adjusted by way of the bypass function on the filter head.

CAPACITÀ DEL FILTRO E IMPOSTAZIONE DEL BYPASS

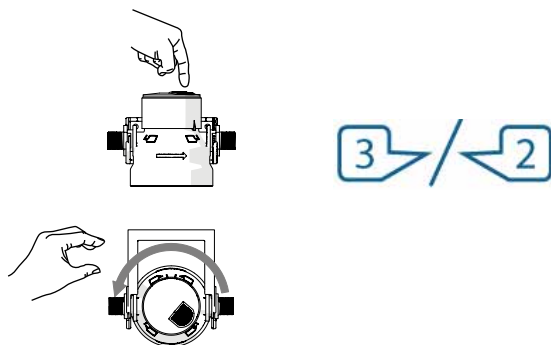

Per regolare l'AQA monitor e il bypass, è necessario conoscere la durezza dell'acqua locale. È possibile richiedere quest'informazione al fornitore dell'acqua oppure ricavarla per mezzo di un rapido test.

Secondo la qualità dell'acqua	Durezza totale in °dF (°dH) ¹	Impostazioni di bypass ²	M200
dolce	<14 (8)	3	2000 l
media	tra 14 e 25 (8 e 14)	3	1140 l
dura	tra 26 e 37 (15 e 21)	2	760 l
molto dura	tra 38 e 50 (22 e 28)	2	570 l
molto, molto dura	>50 (28)	2	460 l

¹ La capacità del filtro specificata è valida per condizioni di prova definite, la capacità effettiva durante il funzionamento può essere maggiore o minore. Sostituire il filtro quando la capacità di cui sopra è esaurita ma al più tardi dopo 12 mesi.

°dF = gradi di durezza francesi °dH = gradi di durezza tedeschi

² Regolare sulla testa di connessione.

L'acqua potabile filtrata corrisponde alla categoria di liquido 2 secondo la norma EN 1717.

La testa di connessione BWT AQA drink è adatta solo alle cartucce filtranti originali BWT AQA drink.

FILTER CAPACITY AND BYPASS SETTING

According to water quality	Total hardness in °dF (°dH) ¹	Bypass settings ²	M200
soft	<14 (8)	3	2000 l
medium	tra 14 e 25 (8 e 14)	3	1140 l
hard	tra 26 e 37 (15 e 21)	2	760 l
Very hard	tra 38 e 50 (22 e 28)	2	570 l
Very, very hard	>50 (28)	2	460 l

¹ While the specified filter capacity is valid for defined test conditions, the actual capacity during operation may be higher or lower. Replace filter when the aforementioned capacity has been reached but at least every 12 months.

°dF = French hardness levels °dH = German hardness levels

² Adjust on the filter head.

The filtered drinking water corresponds to Liquid Category 2 in accordance with EN 1717.

The BWT AQA drink filter head is only suitable for original BWT AQA drink filter cartridges.



MONTAGGIO STAFFA DI SUPPORTO SUPPORT BRACKET ASSEMBLY

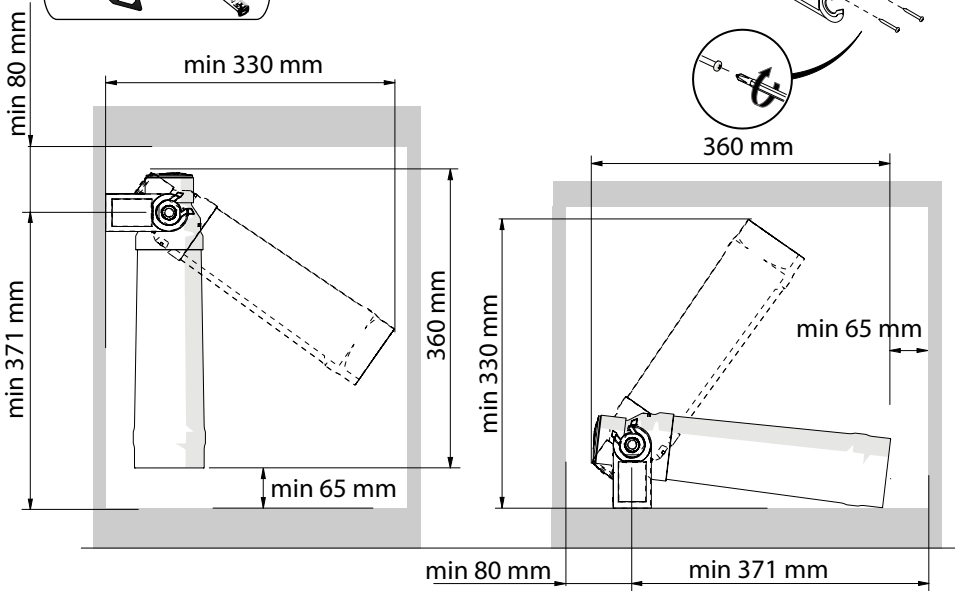
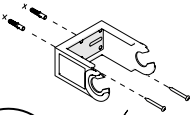

MONTAGGIO TESTA DI CONNESSIONE CONNECTION HEAD ASSEMBLY

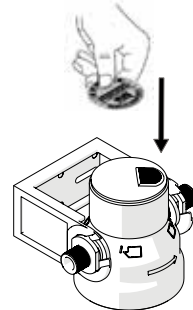
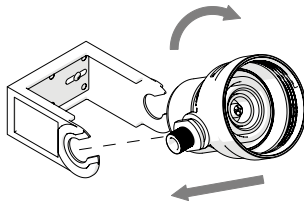

Inserire la testa del filtro nella staffa del filtro, osservare la corretta direzione del flusso.

Insert the filter head into the filter bracket, observe the correct direction of flow.



Sigillare la targhetta di installazione indicando il mese e l'anno di installazione.

Seal the installation plate indicating the month and year of installation.

INSTALLAZIONE DEL CONTATORE ACQUA

Il contatore dell'acqua indica la necessaria sostituzione della cartuccia del filtro in qualsiasi momento.

INSTALLING THE WATER METER

The water meter indicates that the filter cartridge needs to be replaced at any time.

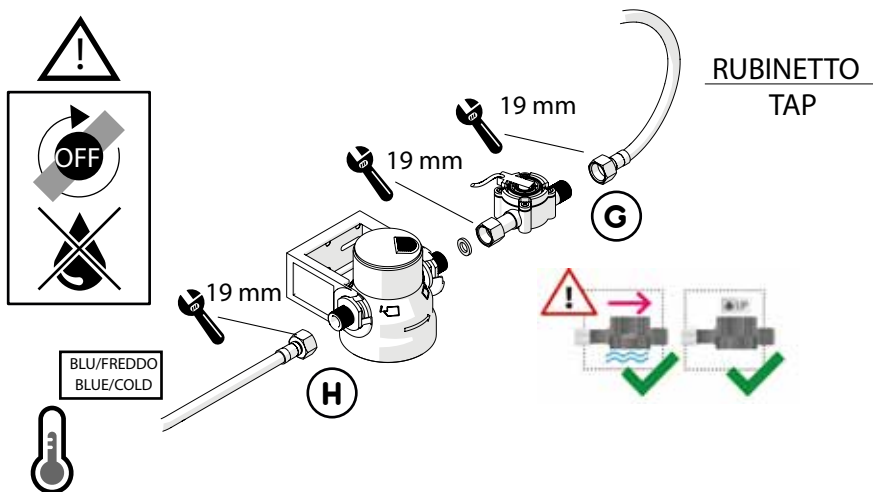

INSTALLAZIONE UNITÀ DI CONTROLLO DELLA CAPACITÀ DEL FILTRO INSTALLING FILTER CAPACITY CONTROL UNIT

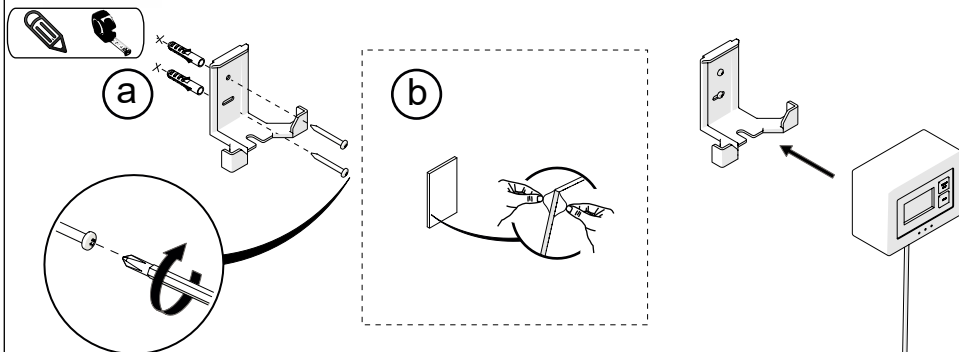
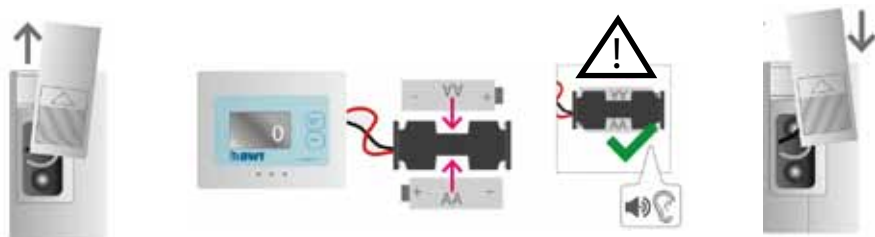

INSTALLAZIONE DELLA CARTUCCIA FILTRANTE

- La cartuccia del filtro può essere installata solo in una testa del filtro BWT originale.
- Lavorare in modo pulito, evitare impurità sul sistema di filtraggio.
- Chiudere la valvola di ritegno/intercettazione prima di sostituire la cartuccia del filtro.

INSTALLING THE FILTER CARTRIDGE

- The filter cartridge may only be installed in a genuine BWT filter head.
- Work cleanly, avoid impurities on the filter system.
- Close the check/shut off valve before exchanging the filter cartridge.

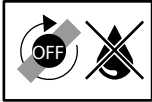

Disimballare la cartuccia del filtro e rimuovere il tappo igienico.
Unpack the filter cartridge and remove the hygienic cap.

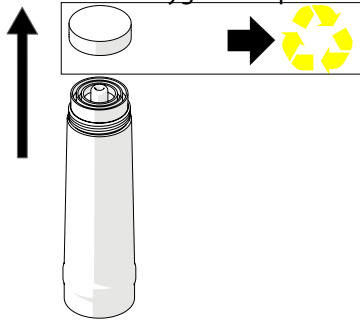

Avvitare la nuova cartuccia del filtro in senso orario nella testa del filtro.
Screw the new filter cartridge clockwise into the filter head.

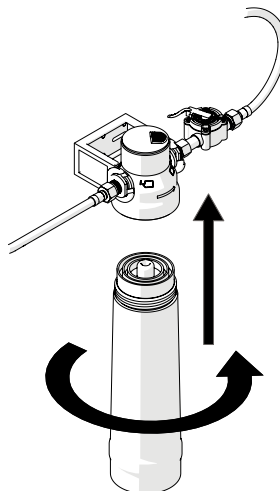

Prima di installare la cartuccia del filtro segnare la data di installazione e sostituzione (non oltre 12 mesi) sulla targhetta della cartuccia del filtro.

Before installing the filter cartridge mark the installation and replacement date (no later than 12 months) on the type label of the filter cartridge.

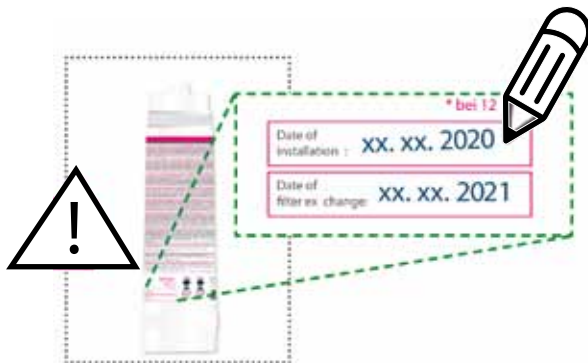

Aprire la valvola di ritegno/intercettazione e controllare che il sistema non presenti perdite.

Open the check/shut off valve and check the system for leaks.

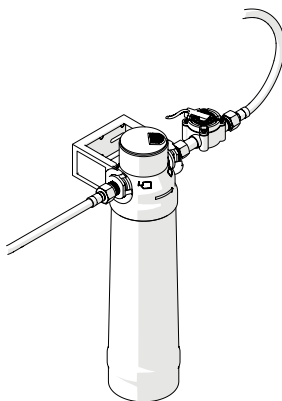
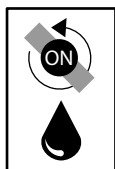

Alla messa in funzione il filtro deve essere risciacquato di 2 litri.

When commissioning, the filter must be rinsed by 2 liters.

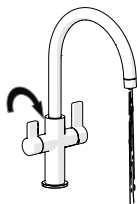
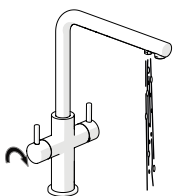

REGOLAZIONE DEL DISPLAY AQA MONITOR

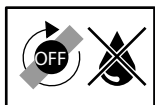

Fare riferimento alle istruzioni specifiche all'interno della confezione AQA Monitor.

Per impostare il contalitri bisogna inserire 2 dati:

- La capacità di filtraggio della cartuccia (litri)
(vedere istruzioni specifiche della cartuccia filtrante o tabella a pagina 9).
- Numero di giorni : 365

ADJUSTING THE AQA MONITOR DISPLAY

Refer to the specific instructions inside the package AQA Monitor .

To set the liter-counter you need to enter 2 data:

- The filtering capacity of the cartridge (liters)
(see specific instructions for the filter cartridge or table on page 9).
- Number of days : 365

SOSTITUZIONE DELLA CARTUCCIA FILTRANTE

Un segnale acustico avverte che sta esaurendo la carica della cartuccia filtrante.

Fare riferimento alle istruzioni specifiche all'interno della confezione della cartuccia filtrante.

Dopo aver inserito una nuova cartuccia filtro si deve resettare la capacità filtro.

REPLACING THE FILTER CARTRIDGE

An acoustic signal warns that the filter cartridge is running out of charge.

Refer to the specific instructions inside the filter cartridge packaging.

After inserting a new filter cartridge, the filter capacity must be reset.

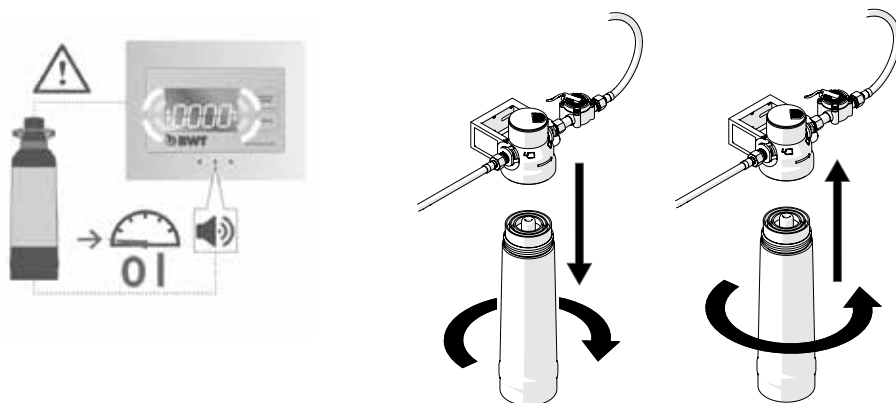

1

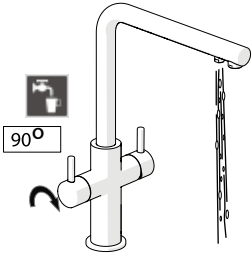

2

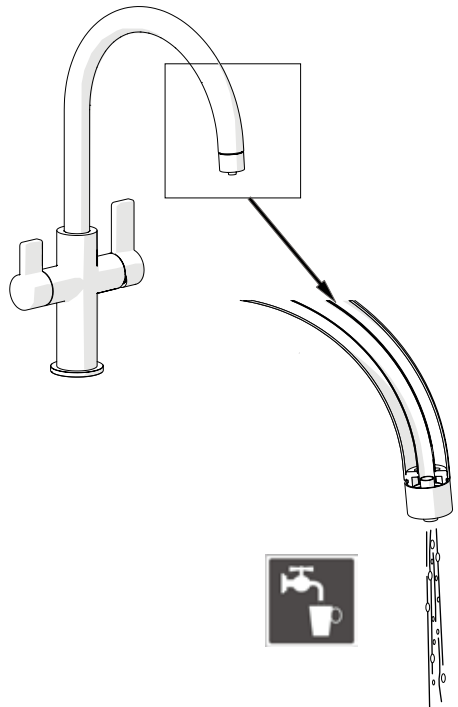
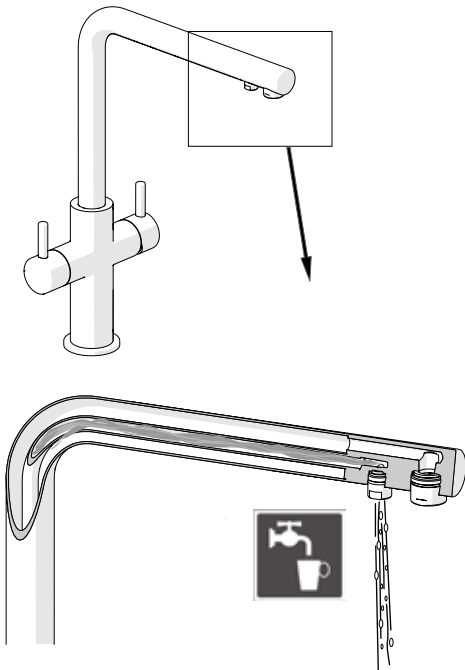
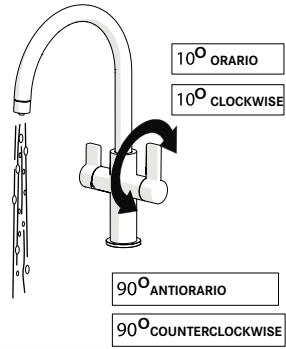
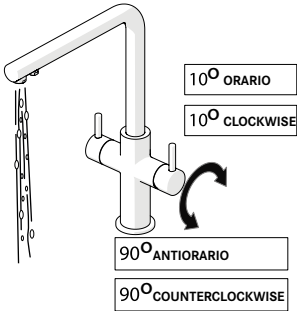
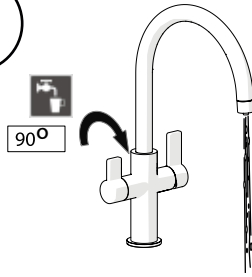



Dispositivo limitatore "dinamico"
della portata d'acqua "50%"
"Dinamic" flow rate restrictor "50%"

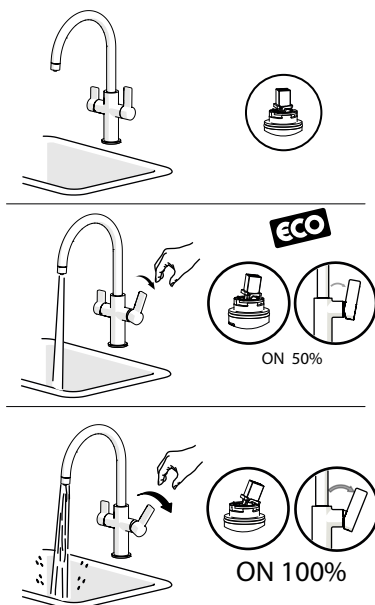
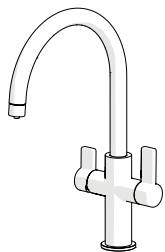

Per limitare la temperatura estrarre il limitatore
e riposizionarlo nella posizione che si desidera
Extract the limiter and put it in correct
position to limit temperature

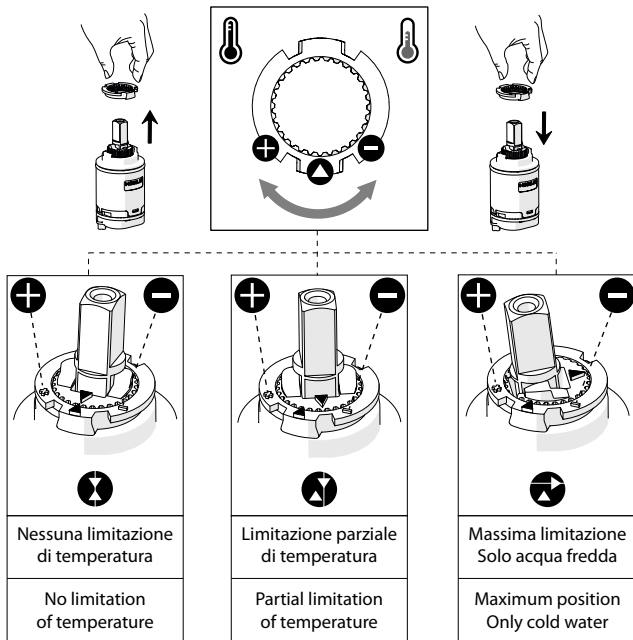

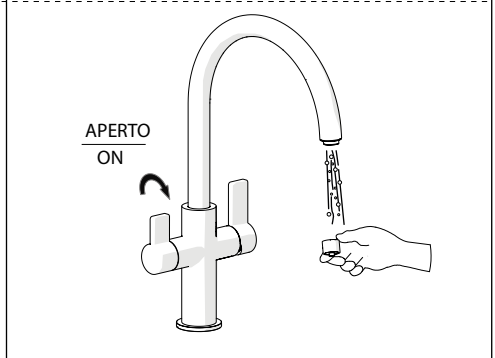
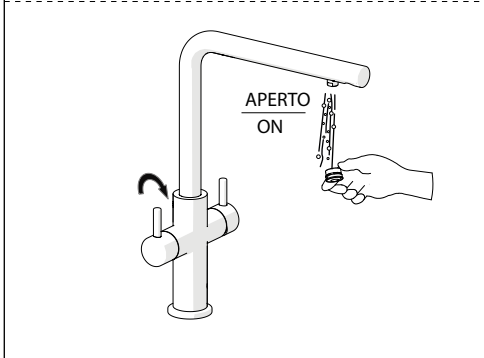
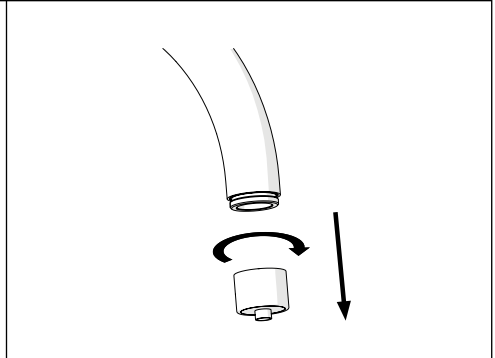
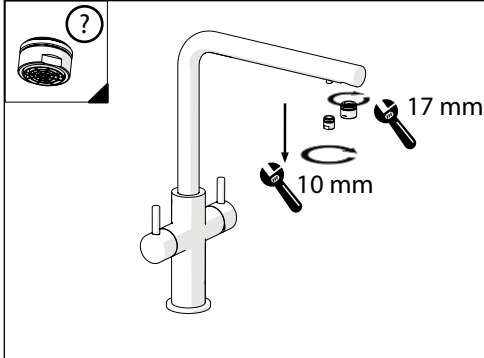
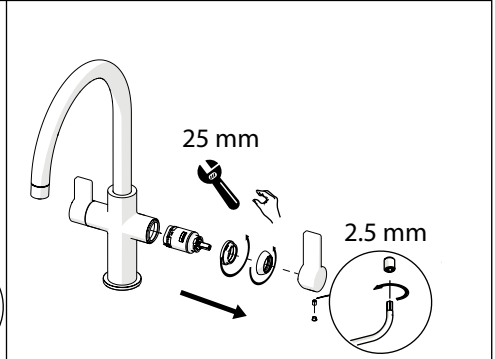
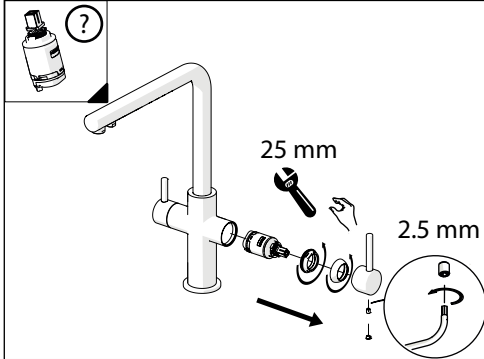
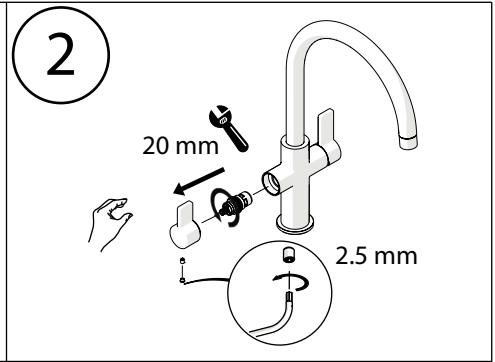
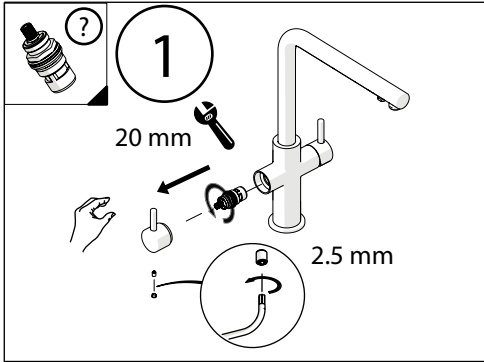

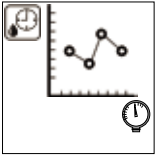

1

PROVA USCITA AERATORE / TEST AERATOR

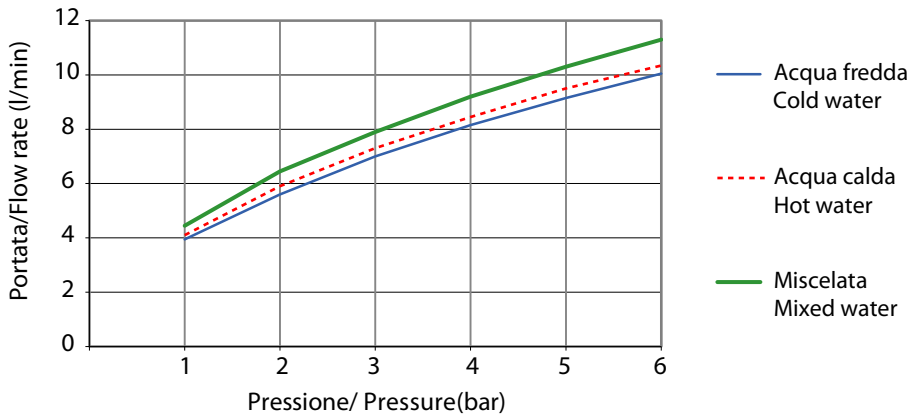

PROVA USCITA ACQUA FILTRATA TEST FILTERED WATER OUTLET

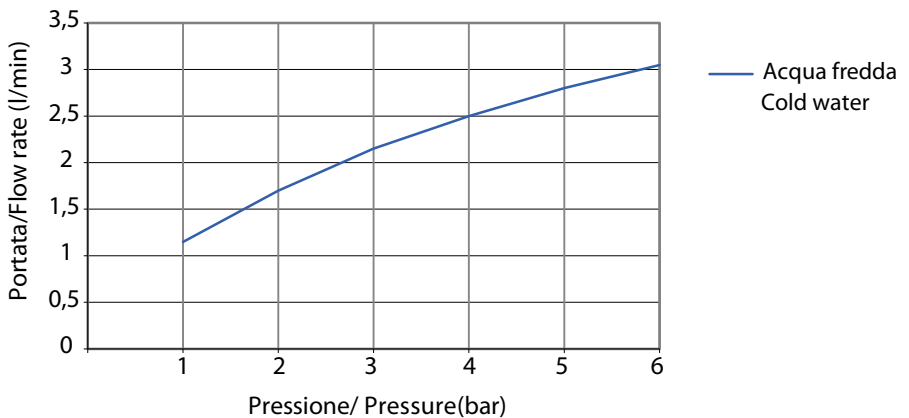

2

PROVA USCITA AERATORE / TEST AERATOR

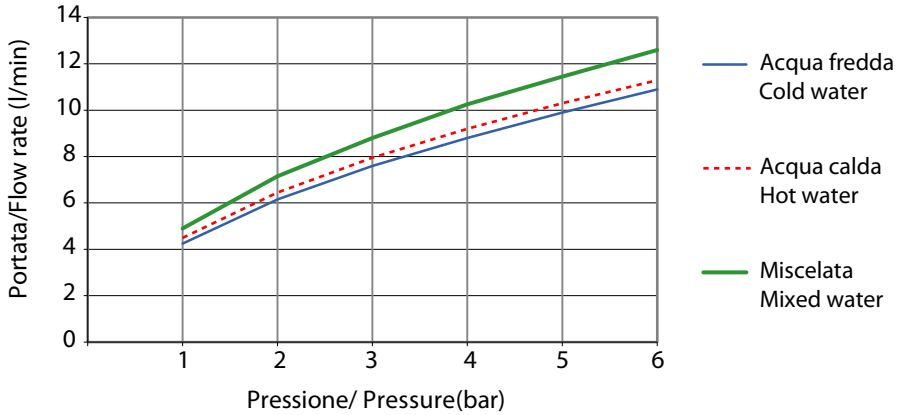

PROVA USCITA ACQUA FILTRATA / TEST FILTERED WATER OUTLET

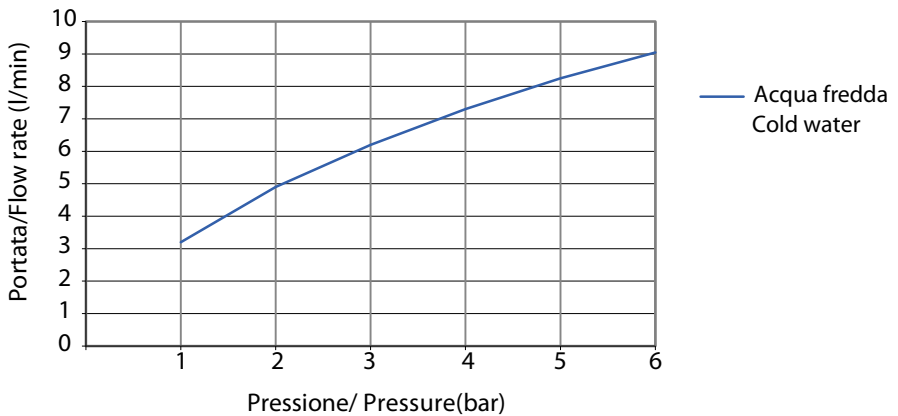

RIPARAZIONE GUASTI SISTEMA FILTRO



L'apparecchio non eroga acqua filtrata	Alimentazione idrica o altre valvole di intercettazione chiuse	Controllare le valvole di intercettazione e, se necessario, aprirle
	Cartuccia filtrante non completamente avvitata nella testa di connessione	Ruotare la cartuccia filtrante di circa ½ giro e riposizionarla finché non si arresta
	Testa di connessione montata in modo errato	Direzione del flusso: controllare la freccia della direzione sulla testa di connessione e, se necessario, invertire la direzione del flusso
Bassa permeabilità all'acqua	La pressione del sistema è troppo bassa	Controllare la pressione del sistema
Aquastop nella testa di connessione presenta perdite se la cartuccia filtrante è rimossa	Deposizione di particelle estranee nell'Aquastop	Sfiatare il sistema con cartuccia filtrante integrata
Perdita della connessione a vite	Guarnizione difettosa	Controllare la tenuta, se necessario sostituirla con una nuova
Bolle d'aria	Sfiato non completo	Ripetere lo sfiato
Acqua lattiginosa/bianca	Formazione di acido carbonico legato al processo, che emerge sotto forma di piccole bolle bianche	Dopo ca. 5 min. la torbidità scompare

TROUBLESHOOTING FILTER SYSTEM



Dispensing of filtered water is not possible	Water supply or other shut-off valves closed	Check shut-off valves and open if necessary
	Filter cartridge not completely screwed into the filter head	Unscrew the filter cartridge by half a turn, and then re-screw it into place to the proper stop.
	Filter head incorrectly mounted	Direction of flow – Check the direction arrow on filter head and reverse it if necessary
Low water throughput (permeability)	System pressure is too low	Check system pressure
Aquastop in filter head is leaky when the filter cartridge is removed	Deposition of foreign particles in the Aquastop	Bleed the system with built-in filter cartridge
Screw connection leaking	Gasket defective	Check the sealing gasket, and replace it with a new one if necessary
Air bubbles	Not completely vented	Repeat venting
Milky/white water	Process-related formation of carbonic acid, which emerges as small white bubbles	After approx. 5 min. the turbidity disappears

SOSTITUZIONE DELLE BATTERIE REPLACING THE BATTERIES

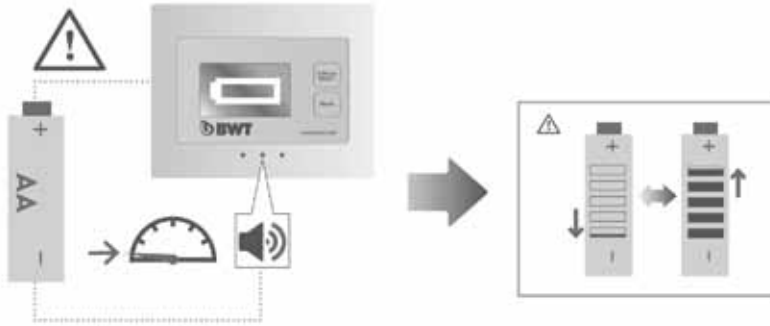

SMALTIMENTO

Se sono disponibili punti di raccolta locali, restituire le cartucce filtranti esaurite, altre parti e imballaggi da riciclare per proteggere l'ambiente. Rispettare le norme locali in vigore!

Smaltire le batterie e le pile nel rispetto dell'ambiente.



Le batterie sono contrassegnate con il simbolo del cestino barrato. È vietato smaltire le batterie insieme ai rifiuti domestici. Sulle batterie contenenti sostanze nocive si trovano i simboli chimici Cd per il cadmio, Hg per il mercurio e Pb per il piombo.

Le batterie e le pile contengono sostanze nocive e risorse preziose. Ogni consumatore è obbligato per legge a restituire tutte le batterie e le pile usate ed esaurite ad un punto di raccolta autorizzato. In questo modo si garantisce che siano riciclati nel rispetto dell'ambiente e delle risorse. Le batterie possono essere restituite gratuitamente dopo l'uso presso il punto vendita o nelle immediate vicinanze. Le batterie difettose possono essere restituite ad un centro di riciclaggio locale.

DISPOSAL

If local collection points are available, return exhausted filter cartridges, other parts and packaging for recycling in the interest of environmental protection. Observe applicable local regulations!

Dispose of conventional and rechargeable batteries in an environmentally friendly manner.



Batteries are marked with the crossed-out dustbin symbol. It is prohibited to dispose of batteries with household waste. Batteries containing harmful substances are marked with the chemical symbols Cd for cadmium, Hg for mercury and Pb for lead.

Both conventional and rechargeable batteries contain harmful substances and valuable resources. Every consumer is legally obligated to return all used and depleted conventional and rechargeable batteries to an approved collection point. This ensures that the batteries are recycled in an environmentally friendly and resource-conserving manner. After use, you can return batteries free of charge to the point of sale or in its immediate vicinity. Defective batteries may be disposed of at a local materials recycling centre.

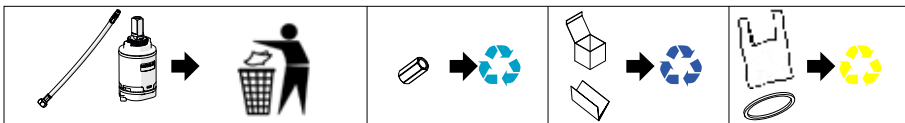

Per TUTTE le indicazioni specifiche sulla cartuccia filtrante e AQA monitor fare riferimento alle istruzioni all'interno delle scatole.

For ALL specific indications on the filter cartridge and AQA monitor refer to the instructions inside the boxes.

PARTI DI RICAMBIO RUBINETTO CONSULTARE IL SITO www.nobili.it
 SPARE PARTS TAP CONSULT THE SITE

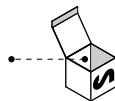

CARTUCCIA FILTRO AQA DRINK AC 100 (OPTIONAL) Capacità 3.000 l (22°F)
FILTER CARTRIDGE AQA DRINK AC 100 (OPTIONAL) Capacity 3.000 l (22°F)

RVR93099

- 1 Prefiltrazione: vengono eliminate le particelle in sospensione.
- 2 Filtrazione a carbone attivo: vengono rimossi odori e sapori, come ad esempio il cloro
- 3 Filtrazione fine: eliminazione delle particelle in sospensione

- 1 Pre-filtration: Removal of particles
- 2 Active carbon filtration: Substances responsible for taste and odor (e.g. chlorine) are removed
- 3 Fine particle filtration: Removal of particles

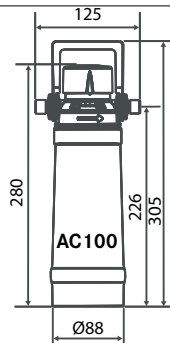

CARTUCCIA FILTRANTE M300 (OPTIONAL)
FILTER CARTRIDGE M300 (OPTIONAL)

RVR93095/M

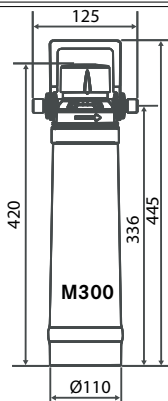

Capacità 3.330 l (22°F)
 Capacity 3.330 l (22°F)

**PULIZIA
 CLEANING**

 ACQUA WATER	 SI CROMO YES CHROME NO PVD ALCOOL ALCOHOL	 MICROFIBRA MICROFIBER	 SPUGNA SPONGE	 DETERGENTI DETERGENT
 TUTTE LE FINITURE ALL FINISHES ACQUA E SAPONE WATER AND SOAP		 ASCIUGARE BENE SEMPRE ALWAYS DRY WELL		

LE ISTRUZIONI DEVONO ESSERE CONSERVATE NELLE IMMEDIATE VICINANZE DEL PRODOTTO

THE INSTRUCTIONS MUST BE KEPT IN THE IMMEDIATE VICINITY OF THE PRODUCT

IISTRAQ93823/3VB#---STD



REV1.02/2023