



SPECIFICATIONS

Single control Velvet black mixer with FENIX NTM® cover
Velvet black
360° swivel spout
Anti limescale aerator M 24 x 1
ø 3/8" stainless steel flexible pipe
50% two step cartridge for water saving

CERTIFICATIONS



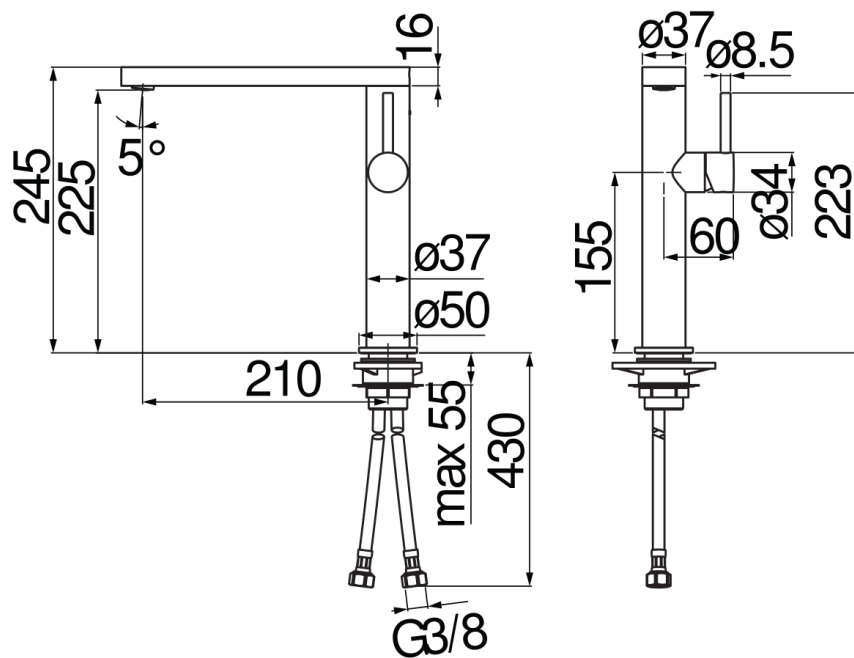

FLOW RATE DIAGRAM: HOT/COLD WATER

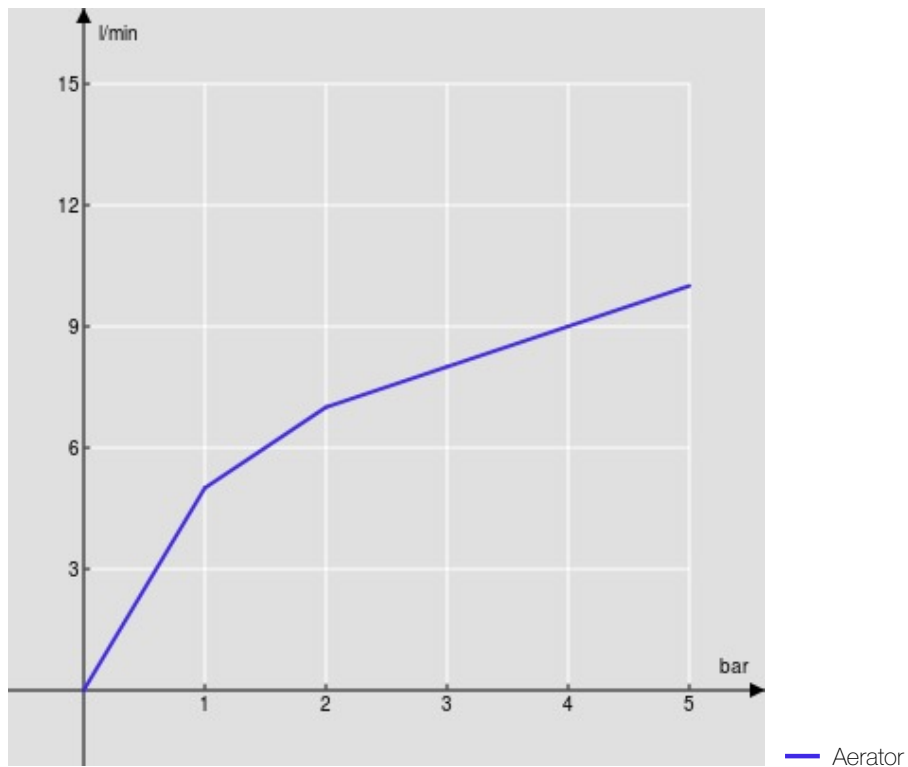

FLOW RATE DIAGRAM: MIXED WATER

